



**AMERICAN SPECIALTIES, INC.**

441 Saw Mill River Road, Yonkers, NY 10701 (914) 476-9000  
www.americanspecialties.com

**0361-PL**

Effective date: April 06  
Supersedes: (all)

**SURFACE MOUNTED AUTOMATIC SOAP DISPENSER REPAIR PARTS**

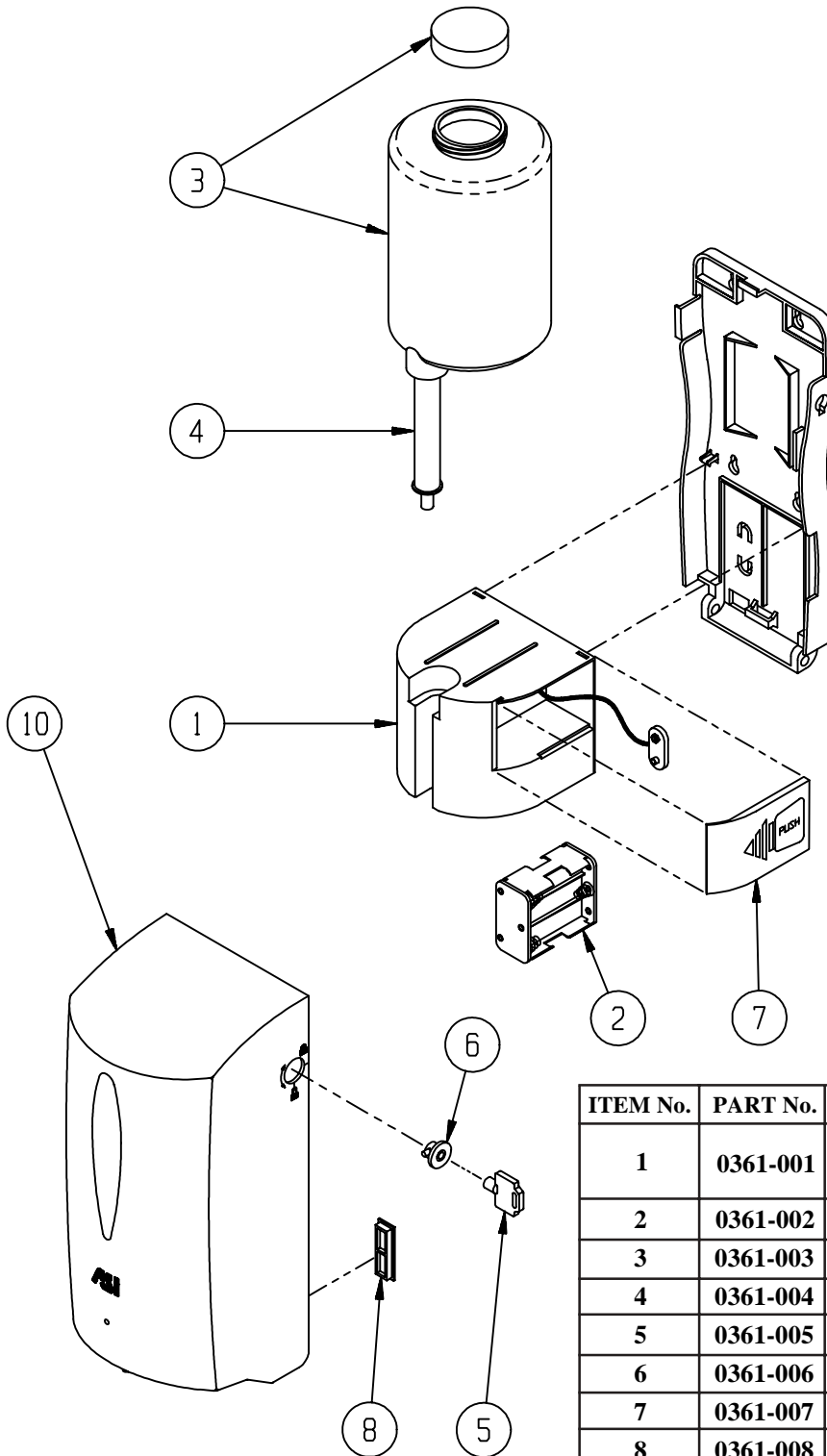

ITEM No.	PART No.	PART DESCRIPTION
1	0361-001	ELECTRONIC BOX w/BATTERY COVER (w/o BATTERY CARRIER)
2	0361-002	BATTERY CARRIER
3	0361-003	SOAP TANK with CAP + DISPENSE VALVE TUBE
4	0361-004	DISPENSE VALVE TUBE only
5	0361-005	KEY
6	0361-006	LOCK
7	0361-007	BATTERY BOX COVER only
8	0361-008	RUBBER PLUG VOLUME ADJUSTER BLOCK
9	0361-009	INSTRUCTION MANUAL (NOT SHOWN)
10	0361-010	FRONT COVER only (WITH VIEW WINDOW)

Accessory Specialties

AMERICAN DISPENSER

Desert Ray Products

**WATROUS** inc.