

# FOR MODEL No's 0362/0363 INSTALLATION INSTRUCTIONS

## 1. SPECIFICATIONS:

Dimensions (W x H x D) {inches (mm)}	4.83 x 10.63 x 4.17 (122 x 270 x 106)
Soap Tank Capacity {fl oz (ml)}	30.4 (900)
Battery Type Required	Alkaline (1.5V) AA size, Qty 4
Battery Life Estimated	10,000 cycles or 1 year
Detection Range Automatic, manually adjustable {inches (mm)}	2.40 (60) ± 1.50 (38)
Room Temperature {°F (°C)}	41 ~ 104 (5 ~ 40)
Sensing Delay Time (msec)	500 ~ 1k
Dispensing Volume {fl oz (ml)}	0.034 ~ 0.051 (1 ~ 1.5)
Applicable Viscosity Range {cP(MPas)}	2000 ~ 5000
Unit Net Weight empty {oz (kg)}	24.7 (0.7)
Operation Mode	Automatic from Sensor Trigger
Supply Reservoir Types	900 ml reusable (included) or 800 ml disposable (supplied by others)
Pump Type	Peristaltic Tube (self contained valve/nozzle)

## 3. BEFORE INSTALLATION:

1. Provide vertical, clean and smooth mounting surface.
2. Make sure there is enough room above dispenser to access cover lock key.
3. Ensure there are no obstructions below unit in sensor zone.
4. Check operation of unit while holding in place by hand **BEFORE** permanent installation

## 4. RECOMMENDED INSTALLATION:

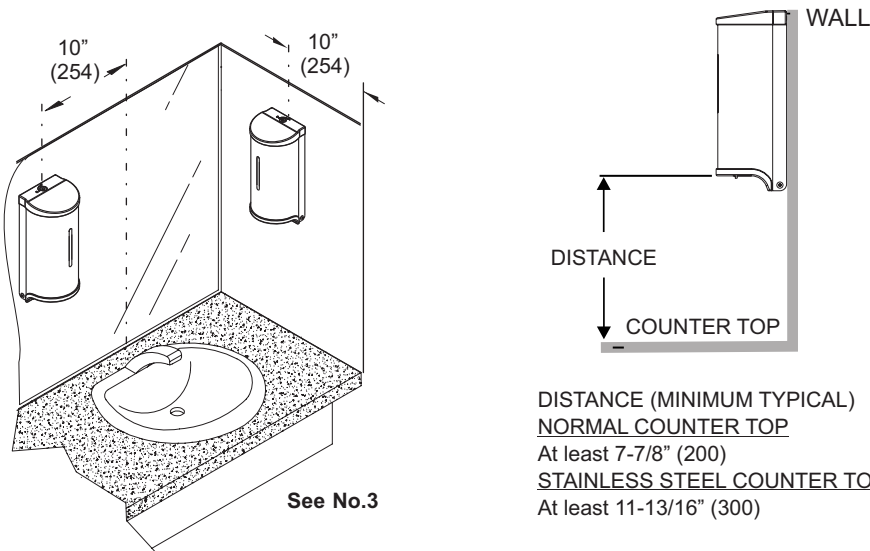

## 2. ITEM LIST:

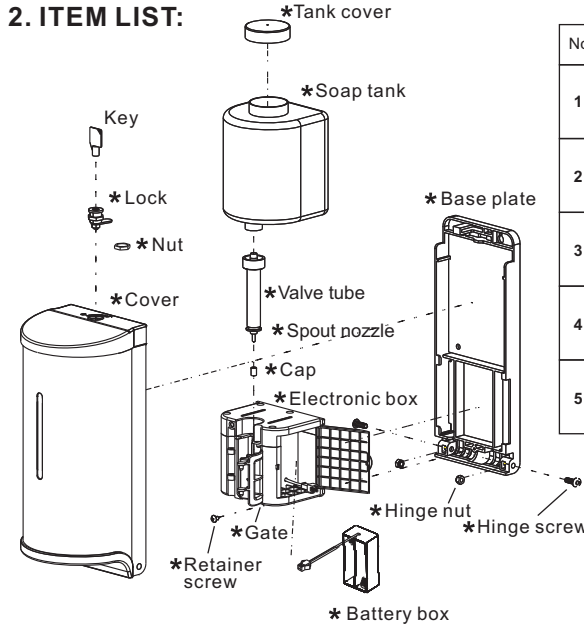

No.	Illustration	Description	Q'ty	No.	Illustration	Description	Q'ty
1		Key on ring	2	6		Mounting screw	4
2		Installation Instructions	1	7		Battery box	1
3		Installation Template	1	8		Replacement soap tank	1
4		Soap Dispenser	1set	9		Lock Nut	1
5		Plastic Anchor	4	10		Replacement cover only	1
				11		Replacement electronic box only w/o battery box	1

\* Items all included in item 4

## 5.1 INSTALLATION STEPS, Tile or Dry Wall

1. Tape the installation template at the appropriate location on the mounting surface.
2. Drill four (4) holes at marked locations 1/4" diameter (Ø6.4).
3. Insert four (4) plastic anchors (supplied) into drilled holes; remove template (fig. 1).
4. Insert two (2) screws (supplied) into top plastic anchors and leave 1/8" (3) space from the wall under head (fig. 2 and fig. 3) for hanging dispenser.
5. Hang the dispenser on the two (2) screws through the keyhole slots at backplate top.
6. Use key to unlock and pull forward the housing cover (fig. 4).
7. Remove soap reservoir and lock dispenser to wall with remaining two (2) screws (supplied) through the holes at backplate bottom. Tighten all screws (fig. 5).

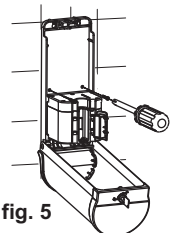
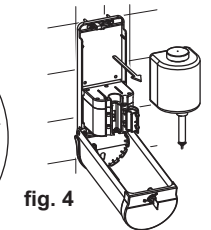
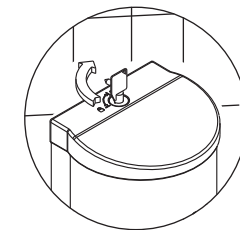
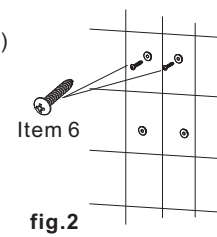
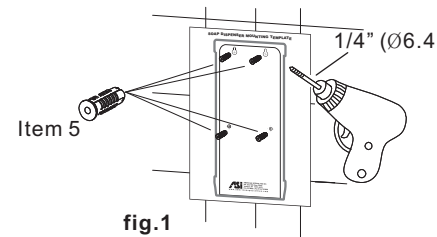

## 5.2 INSTALLATION STEPS, Adhesive on Mirror

1. Clean mounting surface in area to be installed with isopropyl alcohol.
2. Mark outline of dispenser on mirror with masking tape.
3. Remove paper liners from self-adhesive pads on dispenser backplate.
4. Place unit on mounting surface with even steady pressure and hold for 1 minute.
5. Let tape cure for 10 hours prior to filling dispenser with soap for use.

## 7. OPERATION INSTRUCTIONS

### A. Service Instructions

1. Open housing with included security key previously retained.
2. Open cover on battery compartment, remove battery box and unplug cable; install four (4) new Alkaline Type AA 1.5V batteries with correct polarity (note the +/- indication, fig. 7) to obtain 6.0V DC  $\pm$  10% at the plug.
3. Reinstall battery box (note plug polarity tab) and close compartment cover.
4. Obtain a disposable soap cartridge (800ml) or remove, clean out and refill (fig. 8) the included reusable soap reservoir with the correct viscosity liquid soap (ensure that soap container cover is closed and air vent hole is open and nozzle is not clogged and that soap container is clean (no spill-over) and not leaking) and install either in the dispenser. Make sure the nozzle flange is below the housing cradle rib to stretch the valve tube.
5. Make sure to latch the cradle gate.
6. Observe that the LED is lit blue and then flashes three (3) times indicating proper operation "stand-by" condition and battery charge level (push up the cover safety interlock switch (blue stem) on bottom to click and hold it).
7. Close the housing cover and lock it with the included security key previously retained.
8. Trigger the sensor with hands or a towel to check proper soap dispensing cycle (fig. 9).

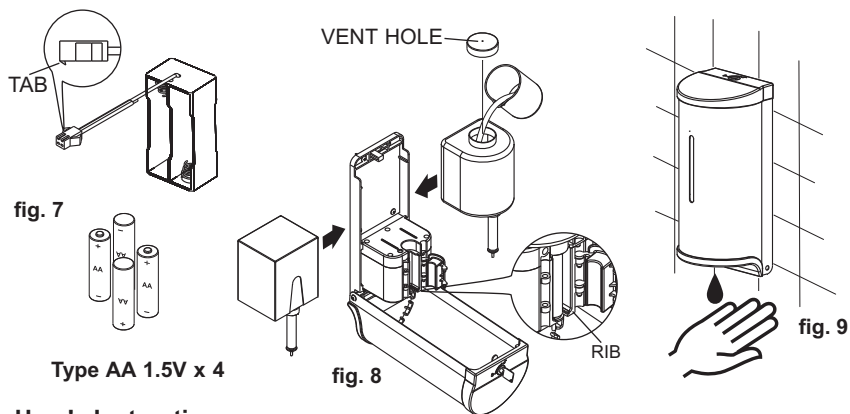

### B. User's Instructions

1. Place hand below the dispenser spout within the sensing range. The dispenser will automatically release the preset amount of liquid soap from the nozzle spout.
2. Obtain additional soap by withdrawing hand and then again placing hand below the dispenser spout within the sensing range.

## 8. SENSING RANGE

Sensing is automatically controlled to set the appropriate distance for the triggering zone. This is based upon mounting height above the counter or floor and the ambient and reflected lighting conditions. There are no user adjustable controls for this feature. It is important to observe the guidelines in Section 4 (on reverse side of these instructions) and install unit above the minimum distance noted for each type of field condition. If lighting conditions change during the life of the installation the unit will automatically readjust itself to accommodate the new environment with no intervention by owner. Countertop reflective quality changes constitute a new environment condition and may require dispenser relocation to just above the appropriate minimum height as noted in Section 4 (on reverse side of these instructions).

## 6. INSTALLATION STEPS CHECK

1. Check to ensure that dispenser is firmly attached to mounting surface.
2. Check to ensure that correct viscosity soap is filled into reservoir.
3. Check to ensure that soap container cover is closed and air vent hole is not blocked.
4. Check to ensure that soap container is clean (no spill-over) and not leaking.
5. Check to ensure that cradle gate is latched on valve tube (lift, push and press down to engage pins to latch or unlatch in reverse operation).
6. Check to ensure that four (4) new Alkaline Type AA batteries are installed with correct polarity (note the +/- indication, fig. 7, and below, typical).
7. Check to ensure that the battery box plug is properly engaged with the cable and the compartment door is closed.
8. Check to ensure that the LED is lit blue and then flashes three (3) times by pushing up the cover safety interlock switch (blue stem) on bottom to click and hold it.
9. Check to ensure that the housing is properly locked and the security key is retained.
10. Check to ensure that the plastic nozzle cap was removed.

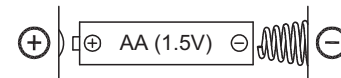

Caution : Batteries installed with incorrect polarity may cause malfunction.

## 9. IMPORTANT NOTICE

1. Ensure no bright source is aimed or reflected at the sensor from below.
2. Use fresh new liquid soap only and clean the soap container properly before each re-fill. Deposits of old soap will lead to malfunction and jamming.
3. Do not dilute liquid soap unless concentrate and do not use soap containing abrasive. Observe indicated viscosity factor of liquid soap.
4. Do not immerse the soap dispenser in water or clean it under running water. This will lead to short circuit.
5. Should the dispenser be out of order and batteries have been replaced, do not attempt any repair work. Call your dealer for professional assistance.

## 10. BATTERY LOW INDICATION

With housing cover open and soap reservoir removed (see Service Instructions) perform the following diagnostic test:

1. Press and push up the cover safety interlock switch (blue stem) on bottom to click and hold it.
2. Observe that the LED is lit blue and then flashes three (3) times indicating proper operation "stand-by" condition and battery charge level.
3. If LED continues to flash blue the indication is positive to replace the batteries.

## 11. TROUBLESHOOTING

Problem Symptom	Solution Diagnostic
No soap dispensed on hands	<ul style="list-style-type: none"> <li>• Check soap qualities, properties and level in reservoir</li> <li>• Check sensor cover for dirt obscuring the lens</li> <li>• Check battery charge level</li> <li>• Check spout nozzle, cap air hole and valve tube for clogs</li> <li>• Check for reflected sensor signals jamming detector</li> </ul>
Battery LED indicator no flash	<ul style="list-style-type: none"> <li>• Replace batteries</li> </ul>
Low volume soap dispensed	<ul style="list-style-type: none"> <li>• Remove soap container and wash out spout nozzle, cap air hole and valve tube and replace with fresh new soap</li> <li>• Check if cradle gate is not properly latched</li> <li>• Check if valve tube is loose in cradle or cross-threaded</li> </ul>
Soap leaks at bottom of housing	<ul style="list-style-type: none"> <li>• Check if valve tube cross-threaded onto bottom of reservoir or reservoir is damaged/punctured</li> <li>• Check disposable soap cartridge for defects and/or replace</li> </ul>