

BABY CHANGING STATION, HORIZONTAL – PLASTIC, SURFACE MOUNTED

Baby Changing Stations

MasterFormat Section 10 28 13

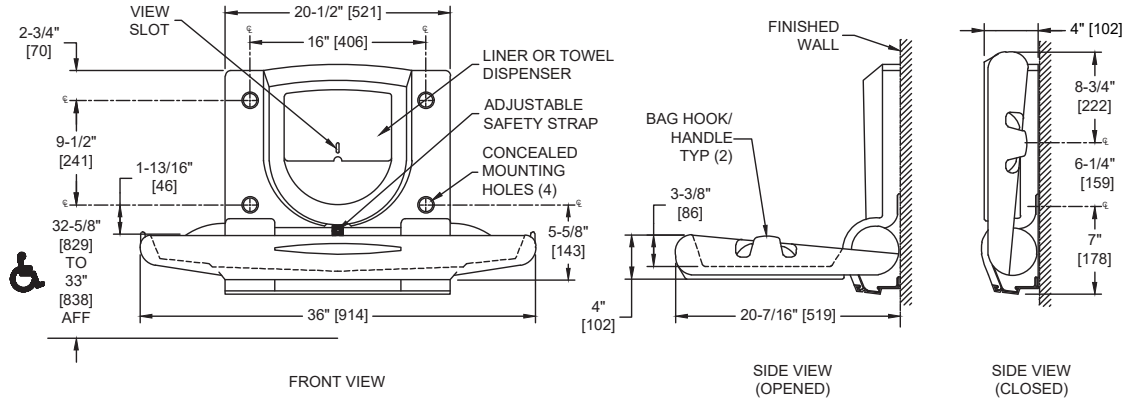

Scan for Information



SUSTAINABILITY/LEED

MR 4.1 (1) MR 6 (1) EQ 4.2 (1)
MR 4.2 (1) EQ 4.1 (1) EQ 4.4 (1)

NOTE:
ALL DIM'S INCH [MM]
ILLUSTRATION FOR REF ONLY AND NTS

PRODUCT OVERVIEW

Modern styling and easy-to-clean surface is fabricated of 100% high-density polyethylene. Unit supports an infant up to 3 ½ years old and a weight up to 50 lbs (23 kg). Tested during development to sustain 250 lbs (113 kg) static load with minimal deflection. Surface mounted. Only 4" [102] deep when closed. Unit platform is shaped to cradle a child's body. Unit is easily opened and closed by user with one hand anywhere on top or front edge of bed or using bag hooks/handle grips on sides. Unit is operable with less than 5lbs force (22.2N) while not requiring any tight grasping, pinching or twisting of the wrist. Bed liner/towel dispenser presents liners or towels for user hygiene and convenience. Dispenser lip retains stack for single liner/towel dispensing. Safety strap is easily adjustable by user for baby size and Sure-Lock latch securely resists opening until released by opposing finger pressure by adult caretaker. Liners/ towels are easily replenished by service personnel as required.

KEY FEATURES & SPECIFICATIONS

- ADA, ASTM F-2285 & F-2388, G-21, G-22, ANSI Z535 and ANSI 117.1 compliant. Damped gas spring aids one handed operation using less than 5lbs force (22.2N) - no tight grasping, pinching or twisting of the wrist.
- Includes two integral bag hooks and a bed-liner dispenser (convertible to a multi-fold towel dispenser).
- Changing Surface is fabricated of FDA-approved fungus and bacteria-resistant HDPE.
- Surface Mounted. Designed to support an infant up to 3 ½ years old and a weight up to 50 lbs (23 kg). Tested during development to sustain 250 lbs (113 kg) static load with minimal deflection.
- The bed is designed to cradle a child's body. An adjustable two-part, vinyl-coated safety strap with a Sure-Lock latch aids in safety.
- Low Profile - Only 4" [102] deep when closed.

OPERATION & MAINTENANCE

Unit platform is shaped to cradle a child's body. Unit is easily opened and closed by user with one hand anywhere on top or front edge of bed or using bag hooks/hand grips on sides. Unit is operable with less than 5 lbf (22.2N) while not requiring any tight grasping, pinching or twisting of the wrist. Bed liner/towel dispenser presents liners or towels for user hygiene and convenience. Dispenser lip retains stack for single liner/towel dispensing. Safety strap is easily adjustable by user for baby size and Sure-Lock latch securely resists opening until released by opposing finger pressure by adult caretaker. Liners/ towels are easily replenished by service personnel as required.

TECHNICAL INFORMATION / PRODUCT PROPERTIES

Property	Value
Dimensions	Closed: 36" x 22" x 4" [914 x 559 x 102] Open: 36" x 22" x 20-7/16" [914 x 559 x 519]
Construction	High-Density Polyethylene (HDPE) FDA-approved fungus and bacteria-resistant plastic bed
Mounting	Surface Mounted
Capacity	Supports an infant up to 3 ½ years old and a weight up to 50 lbs (23 kg). Tested during development to sustain 250 lbs (113 kg) static load with minimal deflection.

INSTALLATION

Surface mount unit using hardware supplied through recessed mounting holes provided. Hardware kit supplied has fasteners suitable for metal or wood stud walls in dry locations and general hollow wall construction where adequate substrate strength is obtained. Fasteners and anchors for masonry walls are not provided. Wall reinforcement must be suitable to sustain transfer of maximum unit loading. Mounting hole plug covers are supplied to conceal fasteners after installation. A template and mounting/operation/maintenance instruction booklet is supplied with each unit. Using mounting dimension on diagram will result in knee clearance under the unloaded bed tray, after installation, of 27" [686] to 27-3/8" [695] and the rim of the changing table will be 30-13/16" [783] to 31-3/16" [792] above finished floor when in horizontal position.

1. Locate wall studs at 16" [406] OC for fastening the station. If two (2) wall studs cannot be used, use two (2) screws into ONE stud and drill pilot holes and install toggle fasteners securely in the wall at non-stud location. Follow dimensions and instructions on installation diagram and Owner's Manual, included with unit.
2. Attach unit to wall studs with four (4) 1/4" x 3" long Philips pan head self-threading screws with flat washers.
3. Where wall studs are not available attach with four (4) 1/4" - 20 x 3" Toggle bolts with flat washers into toggles or expansion nuts.

WARRANTY

Five (5) Years from date of Invoice