



AMERICAN SPECIALTIES, INC.

441 Saw Mill River Road, Yonkers, NY 10701 (914) 476-9000

MODEL No: B6PQ

ISSUED: 5-05

REVISED:

SURFACE MOUNTED LARGE CAPACITY LIQUID SOAP DISPENSER

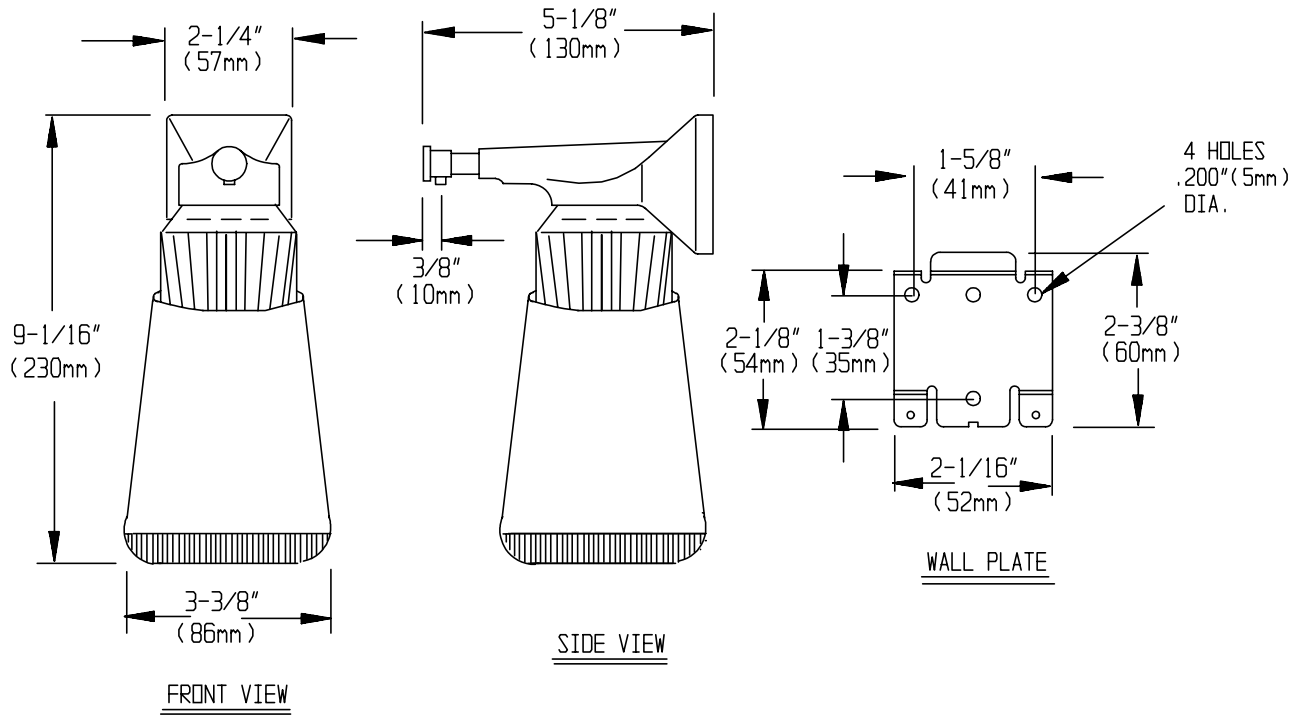

SPECIFICATION

Surface Mounted Large Capacity Soap Dispenser shall dispense a quart (.95 liters) of liquid soap, lotion or synthetic detergent. Dispenser/ Valve unit shall be constructed of chrome-plated brass body with stainless steel and plastic internal parts. Valve operation shall comply with ADA Accessibility Guidelines by requiring no more than 5 lbs_f (22.2 Newtons) pressure to actuate and require no grasping or twisting by operator. Soap "globe" shall be white translucent polyethylene.

Surface Mounted Large Capacity Liquid Soap Dispenser shall be Model N^o B6PQ of American Specialties, Inc., 441 Saw Mill River Road, Yonkers, New York 10701-4913

INSTALLATION

Unit is secured to a wall plate which is surface mounted to wall or partition using N^o10 self-tapping screws (by others). For maximum usability and compliance with ADA Accessibility Guidelines, unit should be installed so that valve is 54" (1371mm) maximum above finished floor (AFF) when clear side access is provided; 48" (1219mm) AFF. with forward reach access only and 46" (1168mm) with side reach over an obstruction (e.g.: vanity). Recommended installation is 42" (1066mm) AFF or 6" (152mm) minimum above washbasin.

OPERATION

Depressing push button manually dispenses soap. Unit is reloaded by unscrewing soap globe from dispenser. Soap will continue to feed properly until empty. Tank supply is replenished manually on cycle determined by maintenance needs.

Accessory Specialties

AMERICAN DISPENSER

Desert Ray Products

WATROUS inc.