



**AMERICAN SPECIALTIES, INC.**  
 441 Saw Mill River Road, NY 10701  
 (914) 476.9000 • (914) 476.0688  
 www.americanspecialties.com

**MODEL №:** 0134

**ISSUED:** 10/12

**REVISED:** 21 May 2013

## TURBO-TUFF™ RECESSED MOUNTED HAND DRYER (PG 1 OF 2)

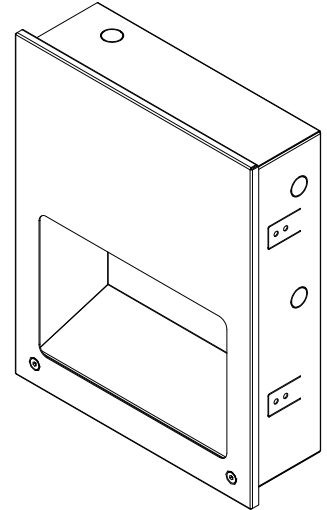
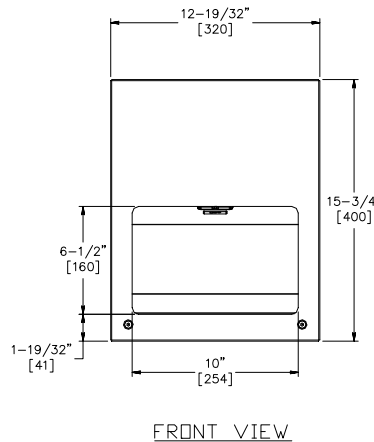
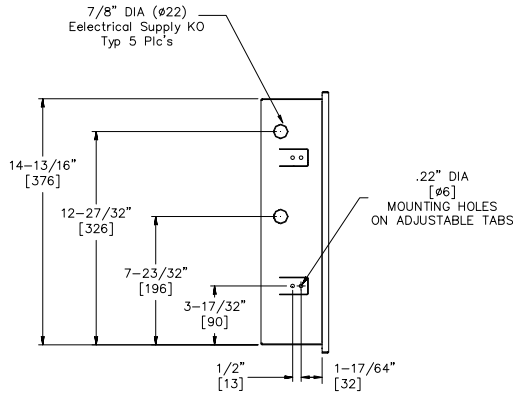
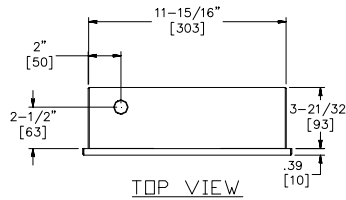

**NOTE:**  
 ALL DIM'S  
 INCH [MM]

### SPECIFICATION

Recess Mounted Hand Dryer shall operate automatically from IR sensor that shall activate dryer when hands are placed in sensor zone. Cover and hand drying chamber shall be 18 gauge type 304 stainless steel alloy 18-8. All exposed surfaces shall have satin finish and shall be protected during shipment by PVC film easily removable after installation. Cabinet shall be 20 gauge corrosion protected steel with a 1/2" (13) wide perimeter trim to lay flush against wall and shall have flush pin-hex security screws to close cover. Motor and heating element shall have internal resetting automatic thermal protection. Fixed directional air vanes shall be heavy duty, rust proof and tamper resistant. Air intake slots shall not allow access to internal parts. Circuitry shall have self-adjusting time-out and fail-safe off protection controlled by a microprocessor that shall detect and reject false signals and shall automatically self calibrate to provide uniform sensitivity over its entire life span. Entire unit shall be internally electrically grounded. Dryer unit shall have approval and be listed under the re-examination services of Underwriters Laboratories, Inc. Unit shall be warranted against defects in materials or workmanship for five (5) years. Owner's Manual (OM) and Mounting Template Installation Guide (MT & IG) are supplied with unit.

Recess Mounted Sensor Hand Dryer shall be Model № 0134 of American Specialties, Inc., 441 Saw Mill River Road, Yonkers, NY 10701-4913

### INSTALLATION

Mount unit cabinet in wall recess with four (4) № 10 (M5) screws (not supplied) into suitably prepared mountings (by others) or other suitable mounting hardware (by others) to suit wall conditions. For masonry walls use expansion bolts or anchors for 1/4" (M6) screws. See unit diagram for electrical service cable rough-in location. Electric service of 100-240VAC 20A 50/60 Hz (provided by others) is brought to RWO at location for dryer indicated on diagram above and is hooked up (by others) in accordance with schematic and Owner's Manual provided with unit. Electrical service is supplied and connected (by others) prior to installing cover. Cover is secured to cabinet with two (2) pin-hex socket flat head security screws (supplied). For compliance with ICC/ANSI A-117.1 and 2010 ADA Accessibility Standards install unit with top of dryer hand chamber 48" (1219) maximum above finished floor (MAX AFF) if clear floor forward or side reach access is provided or 46" (1168) MAX AFF if side reach access over an obstruction (e.g. vanity) with reach depth greater than 10" (254) and less than 25" (635) is only provided or 44" (1118) MAX AFF if forward reach over an obstruction (e.g. commode) with reach depth greater than 20" (508) and less than 25" (635) is only provided. For general utility install unit so that top of dryer hand chamber is 44" to 50" (1118 to 1270) AFF. Note that top of RWO is 9/32" (7) below top of unit. For installation of two or more dryers, dryers should be no closer than 24" (610) on center. See OM and Template MT & IG supplied with unit.

**RWO required is 12-5/16" W x 15-3/16" H x 3-7/8" D minimum (313 x 386 x 98)**

### OPERATION

User activates dryer by placing hands into chamber under sensor. Dryer automatically shuts off after time-out when user removes hands from sensor zone.



**AMERICAN SPECIALTIES, INC.**  
 441 Saw Mill River Road, NY 10701  
 (914) 476.9000 • (914) 476.0688  
 www.americanspecialties.com

**MODEL No: 0134**

ISSUED: 10/12

REVISED: 21 May 2013

**TURBO-TUFF™ RECESSED MOUNTED HAND DRYER (PG 2 OF 2)**

MODEL	TYPE	TIMING	SUPPLY AC VOLTS • HERTZ (HZ)	AMPS (MAX)	WATTS X1000	COVER
0134-1	Hand	Automatic	115-120 • 50/60	10.4	0.84-1.0	Satin Finish; Vertical Grain; 304 Stainless Steel with security screws
0134-2			208-240 • 50/60	5.2	0.75-1.0	
0134-3			277 • 50/60	5.2	1.0	

MOTOR	H/P	RPM	FAN TYPE	AIR FLOW	HEATING ELEMENT	HEAT TEMP.
Brush Type Dual Ball Bearings	0.67	16-29 (ADJ)	Multi-Inlet Centrifugal	42-60 CFM (71-102 m <sup>3</sup> /h) 150-230 ft/s (45-70 m/s)	325-450 Watt with auto reset circuit breaker Range Adjustable by Owner	131° F ± 5 @ 77° F (55° C ± 2.8 @ 25°C) Ambient room temperature

## Circuit diagram

(SEE OWNER'S MANUAL SUPPLIED WITH UNIT)

