



INSTALLATION STEPS Models 0135-1, 0135-2, 0135-3

READ COMPLETELY BEFORE STARTING!

Following steps should be accomplished only by qualified Electrician

TURN OFF POWER TO BRANCH CIRCUIT BEFORE STARTING INSTALLATION STEPS!

1. Remove front panel using security wrench included in kit and retain security screws. Place cover aside with care to protect face finish until required in Step 8.
2. Remove hand drying chamber using #2 Philips screw driver and retain screws. Place chamber aside with care to protect inside finish until required in Step 7.
3. Remove two (2) mounting screws from bottom edge of chassis plate using #2 Philips screw driver and retain screws. Grasp motor securely and lift entire chassis slightly up & over retainer hooks welded to housing top. Place chassis aside with care to protect unit until required in Step 5.
4. Install supplied plastic KO bushing (or other, not supplied) into KO to be used for cable prior to installation of cable into KO or box into RWO (Rough Wall Opening, previously prepared by others). Install wall box housing into RWO locating stub cable into any one (1) of five (5) available KO locations on sides or top of box. Using screws supplied with unit (or other types suitable to wall conditions, by others) tighten screws through adjustable mounting tabs into framing in side walls of RWO to center wall box in opening.
5. Grasp chassis & motor assembly retained in step 3 and slightly lift to place over retainer hooks on housing top to hold unit in place while driving screws. Using #2 Philips screw driver tighten two (2) screws also retained in step 3 through holes on bottom edge of chassis plate into threaded posts on wall box back.
6. Refer to Circuit Diagram on page 3 of Owner's Manual (1703160000 packed with unit & Installation Guide) to match correct wire to terminal block on motor chassis. Pull stub cable through bushing (previously installed, step 4) to allow clearance around hand drying chamber (to be installed next) and enough length to prep ends for terminal block insertion after routing through strain relief clamp on chassis. Clamp cable, prep ends of wires and insert correct wires into terminal block at locations L, N & G. Using a small flat blade screwdriver ensure each wire is properly secured with terminal block top lock screws. See Note B.

Connections: (see fig. 6 & refer to Circuit Diagram) **ENSURE BRANCH CKT BREAKER IS OFF!**

- A. Connect the live wire (colored Brown, Red or Black) to the terminal block marked "L".
- B. Connect the neutral wire (colored Black, Blue, White or Grey) or connect the second live wire (colored Red or Orange) to the terminal block marked "N".
- C. Connect the ground wire to the terminal block marked "⊕" or to the green screw marked "⊕". Bare grounding (earth) wires should be sleeved with green and yellow or green tubing. Colors of live and neutral wires depend on voltage of supply service and requirements of Building and Electrical Code having jurisdiction.

7. Reinstall hand drying chamber retained in step 2 into wall box housing using #2 Philips screw driver and screws also retained in step 2 while being careful to not pinch cable arranged to route clear around hand chamber in step 6.
8. Fasten the front panel onto the chassis box using the two (2) security screws retained in step 1 above using the security wrench. Retain wrench for any possible service access during dryer lifetime. Turn ON breaker at service panel (by others) and test dryer operation.
9. Record the unit S/N on the Registration Card and give this Installation Guide, the Owner's Manual, Registration Post Card and the security wrench to Owner or Facility Manager.

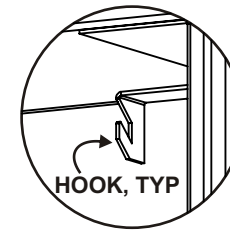

DETAIL 'A' FOR STEP 5

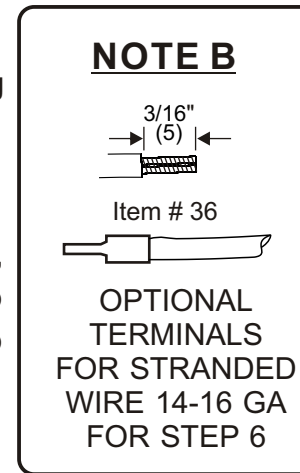

NOTE B
OPTIONAL TERMINALS FOR STRANDED WIRE 14-16 GA FOR STEP 6

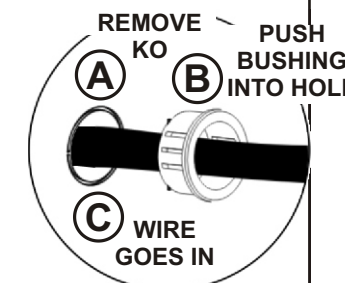

DETAIL OF BUSHING IN STEP 4 TO PUSH INTO KO

