



AMERICAN SPECIALTIES, INC.

441 Saw Mill River Road, Yonkers, NY 10701 (914) 476-9000
www.americanspecialties.com

MODEL No: 045224

ISSUED: 1-87

REVISED: 4-07

RECESSED ROLL PAPER TOWEL DISPENSER

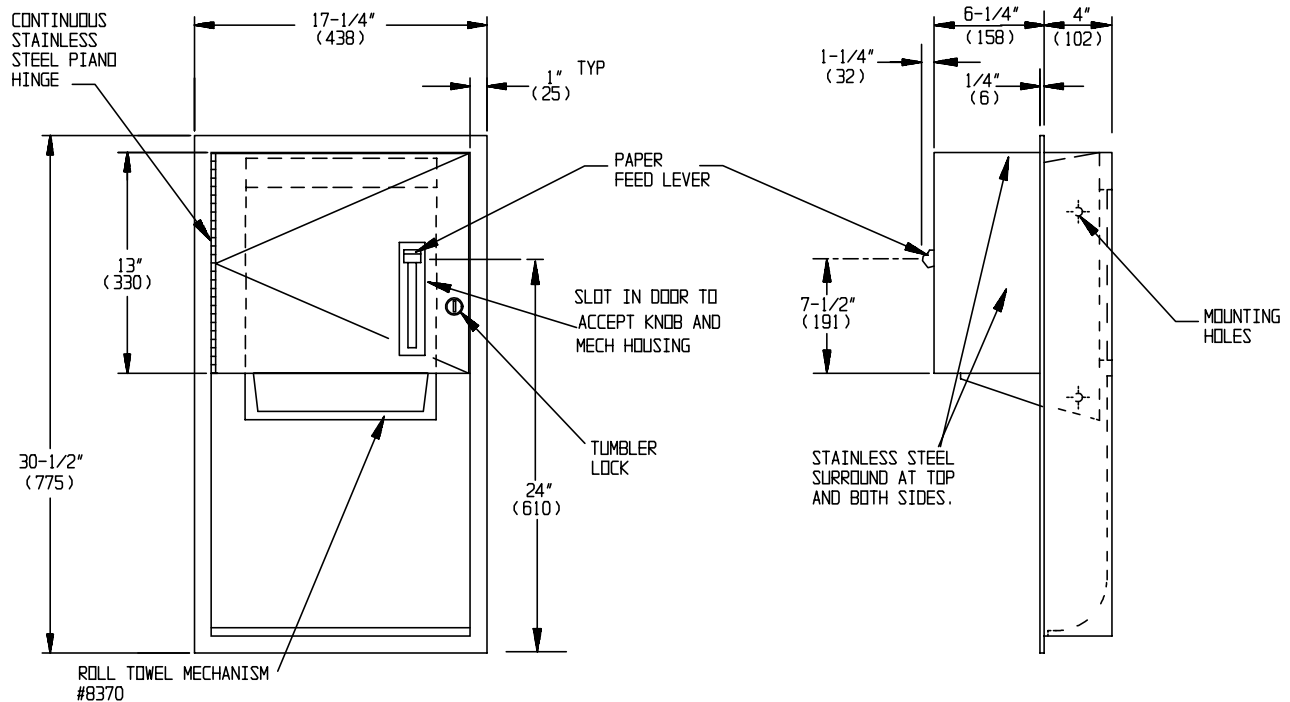

Note:
Dimensions are in inches
and (millimeters)

SPECIFICATION

Recessed Roll Paper Towel Dispenser shall hold and dispense one 8" diameter (Ø203) x 8" or 9" (203 / 229) wide standard towel roll up to 800 ft. (244m) long and one stub roll up to 4" diameter (Ø102). Unit shall be fabricated of 22 gauge type 304 stainless steel alloy 18-8 and rear panel of unit shall be 18 gauge. A lever operated dispensing mechanism shall be supplied. Door shall be attached to cabinet at side with a full length 3/16" diameter (Ø4.8) multi staked piano hinge and shall be held closed with a tumbler lock keyed alike to other ASI washroom equipment. Face trim shall be 1" (25.4) wide formed from one piece with no miters, welding or open seams and shall have a 1/4" (6.4) square return to wall. Structural assembly of all components shall be of welded construction. All exposed surfaces shall have a N° 4 satin finish and shall be protected with PVC film easily removable after installation.

Recessed Roll Paper Towel Dispenser shall be Model N° 045224 as manufactured by American Specialties, Inc., 441 Saw Mill River Road, NY 10701-4913

INSTALLATION

Unit is mounted in wall recess using N° 10 self-tapping screws (by others) through concealed mounting holes provided. For compliance with ADA Accessibility Guidelines, install unit so that towel dispenser lever is 48" (1219) maximum above finished floor (MAX AFF). Note that top of Rough Wall Opening (RWO) is 3/4" (19) below top of unit.

RWO required is 15-3/4" W x 29" H x 4" D minimum (400 x 737 x 102)

OPERATION

Towels are fed by lever action until supply is depleted. Towel feed length is adjustable for economy by pin (supplied) limiting of lever stroke length. Unit may be reloaded with a full roll to automatically start when finished with an existing partial (stub) roll. Locking door prevents unauthorized access and removal.

Accessory Specialties

AMERICAN DISPENSER

Desert Ray Products

WATROUS INC.