

TRI-Umph™ High-Speed Hand Dryer - Silver and Black

Hand Dryers

TRI-Umph

MasterFormat Section 10 28 13

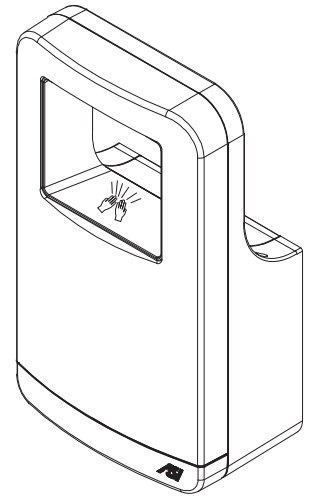
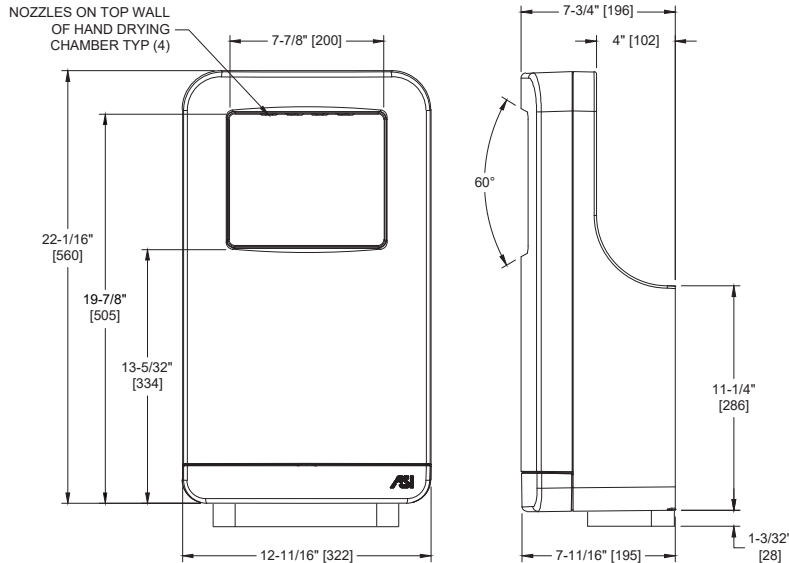

Scan for Information



SUSTAINABILITY/LEED

EAp2 (0)
EA 1 (1-19)

NOTE:
ALL DIM'S INCH [MM]
ILLUSTRATION FOR REF ONLY AND NTS
FOR CLEANING INSTRUCTIONS SEE APPROPRIATE SECTIONS IN
PRODUCT CARE & MAINTENANCE BULLETIN (PCM) ON ASI WEBSITE

PRODUCT OVERVIEW

Satin look cover: ABS plastic with silver ions. Ergonomic—no need to bend over or bend knees. Air blows down and back from vents above. No water splash-back. Ultra hygienic—over 99% of airborne bacteria is eliminated with the removable Triple HEPA Filter System. 5-year warranty. Available in Silver and Black. Optional voltages available. Approved Under the re-examination services of Underwriters Laboratories, Inc.

KEY FEATURES & SPECIFICATIONS

- "No Drip" High Speed Dryer - Ceramic Pad Captures Moisture
- 65 dB-A (Min) - 69.8 dB-A (Max) QUIETER / Fast - Under 15 Sec Dry Time
- Silver & Black ABS Plastic with Anti Microbial Silver Ions
- ADA compliant
- Triple Filter - HEPA, Anti-Microbial, Anti-Odor
- Automatic - AC - Choice 110-120V / 208-/240V / 277V - "No Touch"
- Owner Adjustable Air Speed AND Heat (with On-Off switch)

OPERATION & MAINTENANCE

Automatic "No-Touch"

User activates dryer by placing hands into open hand chamber. LED's change color from amber ready-status to soothing blue to indicate operation. Directional air jets from top blow water droplets off hands onto evaporator plate. Dryer automatically shuts off after time-out (Hold-On) when user removes hands from sensor zone or after 60 seconds if unit is purposefully kept operating for longer than normal drying time (e.g. washroom experimentation, vandalism). Owner may choose to set heater on or off with concealed switch for increased economy based upon 900 Watt operating reduction or may choose to vary/reduce heat output with concealed control between 400 Watts and 900 Watts for user comfort level. Evaporator plate allows atomized droplets to return to vapor state without dripping on floor or back wall behind and below unit. Drip tray prevents excessive waste water from draining onto floor under unit in very heavy usage settings or in high-humidity environments. Security locking screw concealed under filter access drawer prevents unauthorized tampering and protects asset. Triple-Filter element removes airborne solid particles and is changed manually by owner on cycle determined by maintenance requirements. Replacement filters are available from ASI either in carton quantities or in single units. Motor brushes will require replacement under normal intermittent usage conditions approximately every three to four (3-4) years. Complete operating instructions and maintenance information is provided in OM & IG provided with unit.

TECHNICAL INFORMATION / PRODUCT PROPERTIES

Property	Value							
Dimensions	12-11/16" x 23-1/8" x 7-3/4" [322 x 588 x 196]							
Construction	Silver & Black ABS Plastic with Anti Microbial Silver Ions							
Mounting	Surface Mounted - "Touch Free" Operation							
Electrical	Choice of 110-120V / 208/-240V / 277V AC							
Motor	HP	RPM (x1000)	Fan Type	Airflow	Heating Element	Air Output Temperature	Timing	Drying Time
Brush Type Dual Ball Bearings	1	19	Single Inlet Centrifugal with Patented Directional Nozzle Flow Control	55-88 CFM (89-144 m3/h)	Nichrome wire with auto reset circuit breaker	140 °F (60 °C) MAX @ 77 °F (25 °C) Ambient room temperature	Automatic 1 second Hold-On with auto 60 sec shutoff	Less Than 15 Seconds

INSTALLATION

Mount unit cabinet on wall with eight (8) # 10 x 1-1/4" [M5] pan head screws (supplied) through wall plate (provided) into plastic anchors (supplied) or other suitably prepared mountings (by others) or other suitable mounting hardware (by others) to suit wall conditions. Electrical service (see rating per model; provided by others) is either provided to duplex outlet in wall adjacent to unit mounting location or brought to KO location for dryer indicated on diagram prior to installation of unit. Electrical service is supplied and connected (by others) in accordance with schematic and Owner's Manual provided with unit prior to installing access drawer. Cabinet is secured first to wall plate with a concealed pin-hex socket pan head security screw (supplied) and then filter drawer is secured also with a concealed pin-hex socket pan head security screw (supplied). For compliance with ICC/ANSI A-117.1 and 2010 ADA Accessibility Standards install unit with top of dryer hand chamber less than 46-3/4" [1187] maximum Above Finished Floor (AFF). For general utility install unit so that top of dryer hand chamber is 44" [1118] to 50" [1270] AFF. For installation of two or more dryers, units should be no closer than 24" [610] on center. See OM & IG for additional mounting heights for age specific sites.

OPTIONS

Voltage
 20200-1 – 110-120 VAC - 50/60 Hz - 16.2 A (Max.) - 1600W
 20200-2 – 208-240 VAC - 50/60 Hz - 8.1 A (Max.) - 1600W
 20200-3 – 277 VAC - 50/60 Hz - 8.1 A (Max.) - 1600W

WARRANTY

Five (5) Years from date of Invoice