



AMERICAN SPECIALTIES, INC.
 441 Saw Mill River Road, Yonkers, NY 10701
 (914) 476.9000 • (914) 476.0688
 www.americanspecialties.com

MODEL №: 8374

ISSUED: 10/16

REVISED: 18 AUG 2020

AUTOMATIC ROLL TOWEL MECHANISM

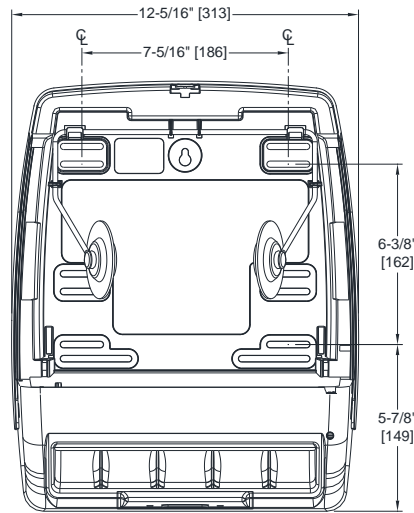

FRONT VIEW

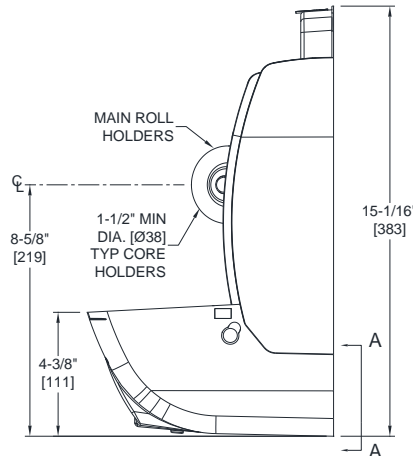

SIDE VIEW

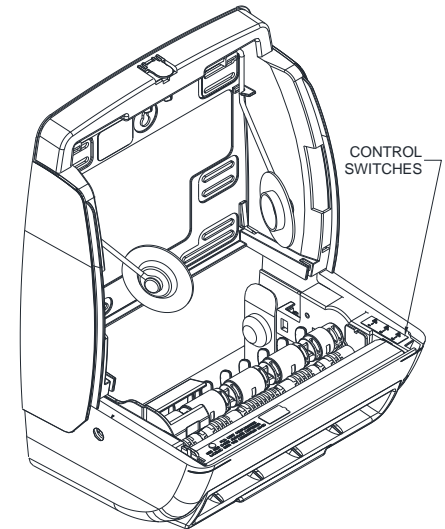

ISOMETRIC

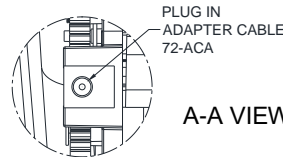

A-A VIEW

NOTE

ALL DIM'S INCH [MM]

ILLUSTRATION FOR REF ONLY AND NTS

SPECIFICATION

Automatic Roll Towel Dispenser Mechanism shall dispense one 8" wide x 8" diameter [203 x Ø203] standard towel roll up to 800 ft. (244m) long and one 8" wide [203] stub roll up to 4" diameter [Ø102]. Automatic Touchless Roll Towel Dispenser shall be powered by four (4) D-size batteries (not supplied) or by C-UL-US and CE approved internal low-voltage adapter (supplied separately, Part# 72-ACA) using 110-240VAC, 50/60 Hz and providing output of 6VDC @ 2A and shall operate automatically to activate towel dispensing when hands are placed in sensor zone. At each activation, unit shall feed out a length of towel selected by owner by setting length, delay and paper saver switches. Unit shall have an internal towel cut-off bar.

NOTE: Unit is designed for installation into automatic paper towel dispenser cabinets manufactured by American Specialties, Inc. Please review Owner's Manual (OM) and/or Installation Guide (IG) for complete instructions.

Automatic Roll Towel Dispenser Mechanism shall be Model № 8374 as manufactured by American Specialties, Inc., 441 Saw Mill River Road, Yonkers, NY 10701-4913

INSTALLATION

Assemble unit onto cabinet back using 1/4"-20x3/8" Philips pan head screws supplied in cabinet through mechanism mounting slots into threaded mechanism mounting holes provided. For compliance with 2010 ADA Accessibility Standards, install cabinet so that towel dispenser slot is 48" [1219] maximum above finished floor (MAX AFF). Be advised that local codes may require mounting so that top of towel dispenser opening is 40" [1016] MAX AFF (e.g. California UBC/Title 24). For general utility, install cabinet with top of towel dispenser opening between 49" and 56" [1245 to 1422] AFF.

OPERATION

Towels are dispensed one length at a time automatically when hands are placed in sensor zone until supply is depleted. Owner predetermines length of towel dispensed by making selections on three (3) three-position switches for length, delay, and economy. Unit may be reloaded with a full roll to automatically start when finished with an existing partial roll and will continue to feed properly when reloaded with a full roll and partial roll is transferred to stub roll position. Refill dispenser by unlocking door of cabinet, removing empty core, and replacing towel roll for an empty or partially empty unit. Dispenser supply is replenished and batteries are replaced manually on cycles determined by maintenance needs. LED indicates sensing and battery condition. Locking cabinet door prevents unauthorized access and roll removal.