

TOP FILL MULTI-FEED TO MEET THE BOTTOM LINE

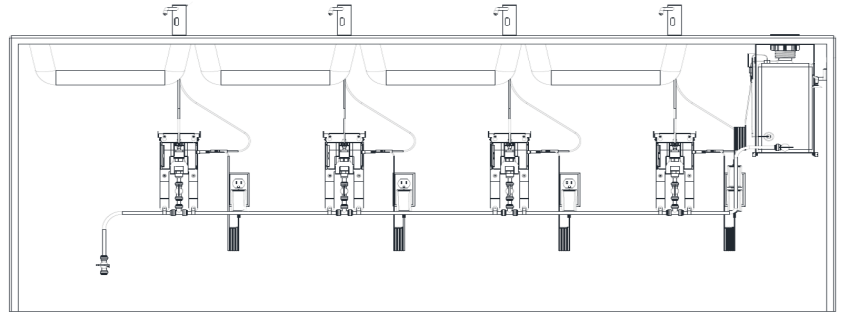

Save time and save your knees with ASI's newest Top Fill Multi-Feed soap dispensing system. Fill up to 12 automatic liquid or foam soap dispensers with one pour using the counter fill port connected to a large capacity, leak-proof tank—a perfect addition to any high traffic washroom.



FEATURES / BENEFITS:

- Battery or AC Powered
- Anti-vandalism fill port cover
- 1.6 gal (6L) foam or liquid, leak-proof soap tank
- One soap tank feeds up to 12* liquid or foam automatic dispensers
- Fill port indicates incorrect soap, low battery, and overfill
- Individual replaceable control pump per dispenser

0387	Top Fill, Multi-Feed - Vanity Mounted Fill Port w/ 6L Under Vanity Tank
0388-1A	Top Fill, Multi-Feed Liquid Soap Dispenser (Batt./not incl) Polished Finish
0388-1AC	Top Fill, Multi-Feed Liquid Soap Dispenser (AC) Polished Finish
0389-1A	Top Fill, Multi-Feed Foam Soap Dispenser (Batt./not incl) Polished Finish
0389-1AC	Top Fill, Multi-Feed Foam Soap Dispenser (AC) Polished Finish

**Max 6 dispensers on each side of tank, see Installation Guide and Owner's Manuals for proper installation.*

WHAT MAKES THIS SOAP DISPENSING SYSTEM UNIQUE?



MULTI-FEED SYSTEM

Each automatic soap dispenser is fed by its own control pump—feeding from a chain of soap supply tubing.

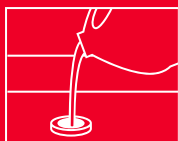

EASY REFILL

Using a single soap reservoir, this top fill system allows refill of multiple soap dispensers with 1 pour—for easy ongoing maintenance.



LARGE TANK

Holds 6 L of liquid or foam soap to supply up to 12 vanity mounted dispensers, excellent for high traffic environments.

SPECIFICATIONS

0387 VANITY MOUNTED TOP FILL PORT W/ TANK FOR AUTO SOAP DISPENSING SYSTEM

Vanity Mounted Top Fill Port with Tank for Vanity Mounted Automatic Soap Dispensing System shall hold 1.6 gal (6 L) of foam or liquid soap of correct viscosity and without abrasive or particulate content to supply individual or chain of multi-unit installation. Supply tank shall be translucent leak-proof seamless molded plastic to continuously provide soap level indication. Unit is powered by AC Adapter (Model № 72-ACA, provided) and is equipped with sensors and LED to indicate low soap level, overflow protection or battery conditions (when powered by Model № 0385-BP available separately). Top Fill Port shall mount on vanity of max thickness 2" [51] through 2-1/4" Dia. [Ø57] hole and tank shall be held in place by mounting bracket. Tank supplies control module (order Model № 0385 or Model № 0386 separately) through supply tube (provided with control module) connected to L-fitting swivel on tank shutoff making possible a supply chain of soap distribution when additional control modules are added (supplied separately) either in LH or RH order to end of vanity. Additional Soap Dispensers (supplied separately) are installed to draw soap from each additional control module. An Owner's Manual and Installation Guide (OM & IG) shall be provided with unit in carton.

0388 AUTOMATIC LIQUID SOAP DISPENSER

Vanity Mounted Automatic Soap Dispensing System Liquid Soap Dispenser shall dispense liquid soap having a pH in range 7 ± 1.5 and within the viscosity range of 5–3000 cP (mPa·s) in stream cycles with volumes of approximately 0.034~0.051 oz (1~1.5 ml) of liquid soap during each activation when connected properly to control-pump module Model № 0386 in appropriately configured system. Dispenser spout body shall be type 304 stainless steel alloy 18-8 and all exposed stainless steel surfaces shall be satin finish. Dispenser shall operate automatically from IR sensor that shall activate dispensing when hands are placed in sensor zone. Sensor detection range shall be preset at $4\text{-}3/4" \pm 1\text{-}1/2"$ [121 ± 38] and shall self-compensate for lighting conditions. An indicator LED shall provide status notification of user sensor detection. Unit shall mount on vanity deck up to 2" [51] thick through 1" Dia. [Ø25] hole minimum to 1-1/4" Dia. [Ø32] max. Soap supply shall be from Control Module (Model № 0386, provided with system) connected to Vanity Mounted Top Fill Tank (Model № 0387, provided when ordered with system) with capacity of 1.6 gal (6 L) of liquid soap containing no abrasives or particulates. An Owner's Manual and Installation Guide (OM & IG) and Mounting Template (MT) shall be provided with unit in carton.

0389 AUTOMATIC FOAM SOAP DISPENSER

Vanity Mounted Automatic Soap Dispensing System Foam Soap Dispenser shall dispense foam soap having a pH in range 7 ± 1.5 and within the viscosity range of 1–100 cP (mPa·s) in stream cycles with foam volume ranging approximately 0.24 ~ 0.3 oz [7 ~ 9 ml] using 0.02 ~ 0.03 oz [0.7 ~ 0.9 ml] liquid for each activation. Dispenser spout body shall be type 304 stainless steel alloy 18-8 and all exposed stainless steel surfaces shall be satin finish. Dispenser shall operate automatically from IR sensor that shall activate dispensing when hands are placed in sensor zone. Sensor detection range shall be preset at $4\text{-}3/4" \pm 1\text{-}1/2"$ [121 ± 38] and shall self-compensate for lighting conditions. An indicator LED shall provide status notification of user sensor detection. Unit shall mount on vanity deck up to 2" [51] thick through 1" Dia. [Ø25] hole minimum to 1-1/4" Dia. [Ø32] max. Soap supply shall be from Control Module (Model № 0385, provided with system) connected to Vanity Mounted Top Fill Tank (Model № 0387, provided when ordered with system) with capacity of 1.6 gal (6 L) of liquid soap containing no abrasives or particulates. An Owner's Manual and Installation Guide (OM & IG) and Mounting Template (MT) shall be provided with unit in carton.

